

COMMON ENTRANCE TEST - 2011

DATE	SUBJECT	TIME
28-04-2011	PHYSICS	10.30 AM to 11.50 AM
MAXIMUM MARKS	TOTAL DURATION	MAXIMUM TIME FOR ANSWERING
60	80 MINUTES	70 MINUTES

MENTION YOUR CET NUMBER	QUESTION BOOKLET DETAILS	
	VERSION CODE	SERIAL NUMBER
	B - 2	894278

DOs :

1. Check whether the CET No. has been entered and shaded in the respective circles on the OMR answer sheet.
2. This Question Booklet is issued to you by the Invigilator after the 2nd Bell, i.e., after 10.30 a.m.
3. The Serial Number of this question booklet should be entered on the OMR answer sheet.
4. The Version Code of this question booklet should be entered on the OMR answer sheet and the respective circles should be shaded completely.
5. Compulsory sign at the bottom portion of the OMR answer sheet in the space provided.

DON'Ts :

1. The timing and marks printed on the OMR answer sheet should not be damaged/mutilated/spoiled.
2. The 3rd Bell rings at 10.40 a.m. till then;
 - Do not remove the seal/staple present on the right hand side of this question booklet.
 - Do not look inside this question booklet.
 - Do not start answering on the OMR answer sheet.

IMPORTANT INSTRUCTIONS TO CANDIDATES

1. This question booklet contains 60 questions and each question will have one statement and four distracters (four different options / choices).
2. After the 3rd Bell is rung at 10.40 a.m., remove the seal/staple present on the right hand side of this question booklet and start answering on the OMR answer sheet.
3. During the subsequent 70 minutes :
 - Read each question carefully.
 - Choose the correct answer from out of the four available distracters (options/choices) given under each question/statement.
 - Completely **darken/shade** the relevant circle with a **BLUE OR BLACK INK BALLPOINT PEN** against the question number on the OMR answer sheet.

CORRECT METHOD OF SHADING THE CIRCLE ON THE OMR SHEET IS AS SHOWN BELOW :



4. Please note that even a minute unintended ink dot on the OMR sheet will also be recognized and recorded by the scanner. Therefore, avoid multiple markings of any kind on the OMR answer sheet.
5. Use the space provided on each page of the question booklet for Rough Work. Do not use the OMR answer sheet for the same.
6. After the last bell is rung at 11.50 a.m., stop writing on the OMR answer sheet and affix your LEFT HAND THUMB IMPRESSION on the OMR answer sheet as per the instructions.
7. Hand over the OMR answer sheet to the room Invigilator as it is.
8. After separating and retaining the top sheet (KEA Copy), the Invigilator will return the bottom sheet replica (Candidate's copy) to you to carry home for self-evaluation.
9. Preserve the replica of the OMR answer sheet for a minimum period of ONE year.

PHYSICS

1. Two identical charged spheres of material density ρ , suspended from the same point by inextensible strings of equal length make an angle θ between the strings. When suspended in a liquid of density σ the angle θ remains the same. The dielectric constant K of the liquid is

1) $\frac{\rho}{\rho + \sigma}$ 2) $\frac{\rho + \sigma}{\rho}$ 3) $\frac{\rho}{\rho - \sigma}$ 4) $\frac{\rho - \sigma}{\rho}$

2. The electric field at a point due to an electric dipole, on an axis inclined at an angle $\theta (< 90^\circ)$ to the dipole axis, is perpendicular to the dipole axis, if the angle θ is

1) $\tan^{-1}(\sqrt{2})$ 2) $\tan^{-1}\left(\frac{1}{\sqrt{2}}\right)$ 3) $\tan^{-1}(2)$ 4) $\tan^{-1}\left(\frac{1}{2}\right)$

3. In the circuit shown, the currents i_1 and i_2 are

1) $i_1 = 1 \text{ A}, i_2 = 3 \text{ A}$
 2) $i_1 = 3 \text{ A}, i_2 = 1 \text{ A}$
 3) $i_1 = 1.5 \text{ A}, i_2 = 0.5 \text{ A}$
 4) $i_1 = 0.5 \text{ A}, i_2 = 1.5 \text{ A}$

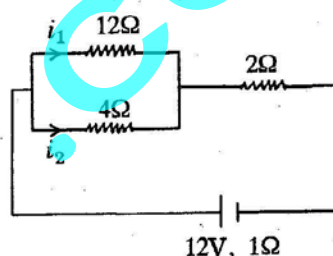

4. In the given network, the value of C , so that an equivalent capacitance between A and B is $3\mu\text{F}$, is

1) $48 \mu\text{F}$
 2) $36 \mu\text{F}$
 3) $\frac{1}{5} \mu\text{F}$
 4) $\frac{31}{5} \mu\text{F}$

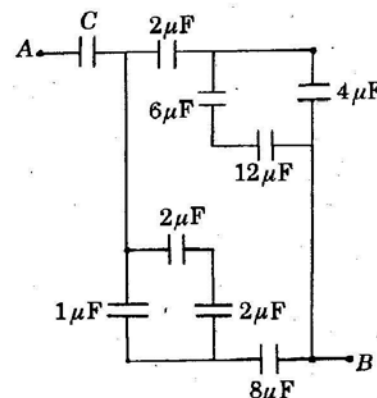

5. A conductor wire having 10^{29} free electrons/ m^3 carries a current of 20A. If the cross-section of the wire is 1mm^2 , then the drift velocity of electrons will be ($e = 1.6 \times 10^{-19} \text{ C}$).

1) $1.25 \times 10^{-5} \text{ ms}^{-1}$ 2) $6.25 \times 10^{-3} \text{ ms}^{-1}$
 3) $1.25 \times 10^{-4} \text{ ms}^{-1}$ 4) $1.25 \times 10^{-3} \text{ ms}^{-1}$

(Space for Rough Work)

16. Wavefront is the locus of all points, where the particles of the medium vibrate with the same
- 1) frequency
 - 2) period
 - 3) phase
 - 4) amplitude
17. Two monochromatic light waves of amplitudes $3A$ and $2A$ interfering at a point have a phase difference of 60° . The intensity at that point will be proportional to
- 1) $7A^2$
 - 2) $19A^2$
 - 3) $5A^2$
 - 4) $13A^2$
18. Consider the following statements in case of Young's double slit experiment.
- a) A slit S is necessary if we use an ordinary extended source of light.
 - b) A slit S is not needed if we use an ordinary but well collimated beam of light.
 - c) A slit S is not needed if we use a spatially coherent source of light.
- Which of the above statements are correct?
- 1) b) and c)
 - 2) a) and c)
 - 3) a), b) and c)
 - 4) a) and b)
19. A parallel beam of light of wavelength 6000 \AA gets diffracted by a single slit of width 0.3 mm . The angular position of the first minima of diffracted light is
- 1) $1.8 \times 10^{-3} \text{ rad}$
 - 2) $6 \times 10^{-3} \text{ rad}$
 - 3) $2 \times 10^{-3} \text{ rad}$
 - 4) $3 \times 10^{-3} \text{ rad}$
20. The critical angle of a certain medium is $\sin^{-1}\left(\frac{3}{5}\right)$. The polarizing angle of the medium is
- 1) $\tan^{-1}\left(\frac{3}{4}\right)$
 - 2) $\tan^{-1}\left(\frac{4}{3}\right)$
 - 3) $\sin^{-1}\left(\frac{4}{5}\right)$
 - 4) $\tan^{-1}\left(\frac{5}{3}\right)$

(Space for Rough Work)

26. A resistor has a colour code of green, blue, brown and silver. What is its resistance?

- 1) $560\Omega \pm 5\%$
- 2) $5600\Omega \pm 10\%$
- 3) $56\Omega \pm 5\%$
- 4) $560\Omega \pm 10\%$

27. The voltage V and current I graphs for a conductor at two different temperatures T_1 and T_2 are shown in the figure. The relation between T_1 and T_2 is

- 1) $T_1 = T_2$
- 2) $T_1 = \frac{1}{T_2}$
- 3) $T_1 > T_2$
- 4) $T_1 < T_2$

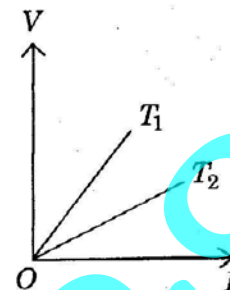

28. Consider the following statements regarding the network shown in the figure.

- a) The equivalent resistance of the network between points A and B is independent of value of G .
- b) The equivalent resistance of the network between points A and B is $\frac{4}{3}R$.
- c) The current through G is zero.

Which of the above statements is/are TRUE?

- 1) b) and c)
- 2) a), b) and c)
- 3) a) alone
- 4) b) alone

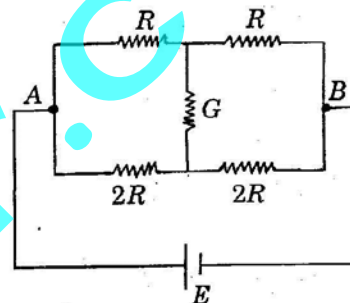

29. The torque required to hold a small circular coil of 10 turns, area 1 mm^2 and carrying a current of $\left(\frac{21}{44}\right)\text{A}$ in the middle of a long solenoid of 10^3 turns/m carrying a current of 2.5A , with its axis perpendicular to the axis of the solenoid is

- 1) $1.5 \times 10^{-6}\text{ N-m}$
- 2) $1.5 \times 10^{-8}\text{ N-m}$
- 3) $1.5 \times 10^{-6}\text{ N-m}$
- 4) $1.5 \times 10^{-8}\text{ N-m}$

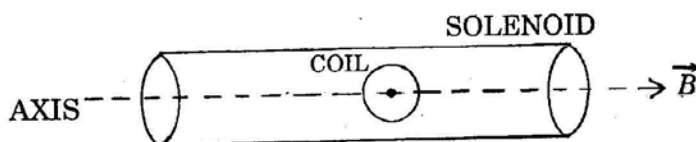

30. A particle of charge e and mass m moves with a velocity v in a magnetic field B applied perpendicular to the motion of the particle. The radius r of its path in the field is

- 1) $\frac{ev}{Bm}$
- 2) $\frac{Bv}{em}$
- 3) $\frac{mv}{Be}$
- 4) $\frac{Be}{mv}$

(Space for Rough Work)

36. Two capillary tubes of different diameters are dipped in water. The rise of water is

- 1) greater in the tube of smaller diameter
- 2) independent of the diameter of the tube
- 3) the same in both tubes
- 4) greater in the tube of larger diameter

37. A perfect gas at 27°C is heated at constant pressure so as to double its volume. The increase in temperature of the gas will be

- 1) 54°C
- 2) 300°C
- 3) 600°C
- 4) 327°C

38. Three identical rods A , B and C are placed end to end. A temperature difference is maintained between the free ends of A and C . The thermal conductivity of B is **THRICE** that of C and **HALF** of that of A . The effective thermal conductivity of the system will be (K_A is the thermal conductivity of rod A).

- 1) $2 K_A$
- 2) $\frac{2}{3} K_A$
- 3) $\frac{1}{3} K_A$
- 4) $3 K_A$

39. The quantities of heat required to raise the temperatures of two copper spheres of radii r_1 and r_2 ($r_1 = 1.5 r_2$) through 1 K are in the ratio of

- 1) $\frac{3}{2}$
- 2) 1
- 3) $\frac{27}{8}$
- 4) $\frac{9}{4}$

40. Which one of the following is $\nu_m - T$ graph for perfectly black body? ν_m is the frequency of radiation with maximum intensity. T is the absolute temperature.

- 1) C
- 2) D
- 3) A
- 4) B

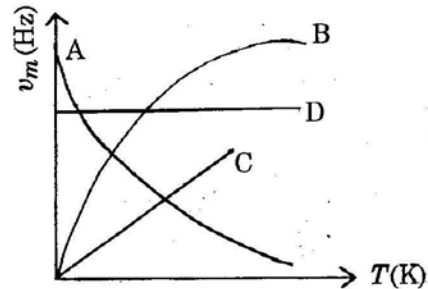

(Space for Rough Work)

51. An *n-p-n* transistor can be considered to be equivalent to two diodes, connected. Which of the following figures is the CORRECT ONE?

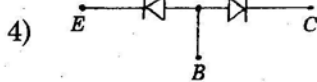
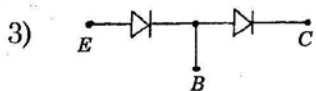
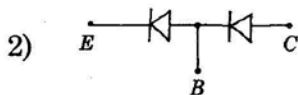
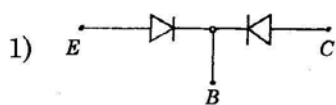

52. In the case of forward biasing of a *p-n* junction diode, which one of the following figures correctly depicts the direction of conventional current (indicated by an arrow mark)?

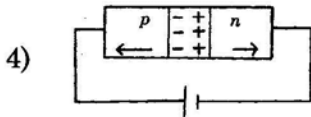
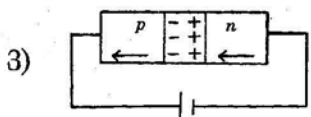
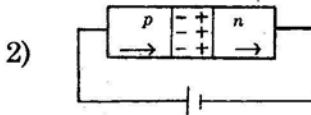
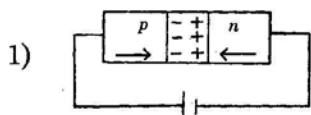

53. An electron of mass m_e and a proton of mass m_p are moving with the same speed.

The ratio of their de-Broglie's wavelengths λ_e/λ_p is

1) $\frac{1}{1836}$

2) 918

3) 1

4) 1836

54. The output of given logic circuit is

1) $(A + B) \cdot (A + C)$

2) $A + B + C$

3) $A \cdot (B + C)$

4) $A \cdot (B \cdot C)$

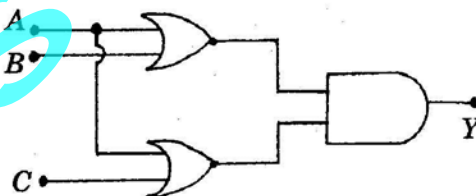

55. If the scattering intensity of a liquid is 8 units at a wavelength of 500 nm, then the scattering intensity at a wavelength of 400 nm will be approximately

1) 20 units

2) 24 units

3) 13 units

4) 16 units

(Space for Rough Work)

56. A neutron, a proton, an electron and an α -particle enter a region of uniform magnetic field with the same velocities. The magnetic field is perpendicular and directed into the plane of the paper. The tracks of the particles are labelled in the figure. The electron follows the track

- 1) C
- 2) D
- 3) A
- 4) B

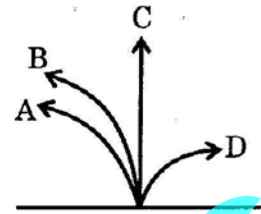

57. The deflection in a moving coil galvanometer is reduced to half when it is shunted with a 40Ω coil. The resistance of the galvanometer is

- 1) 20Ω
- 2) 15Ω
- 3) 80Ω
- 4) 40Ω

58. A current of $\left(\frac{2}{\sqrt{3}}\right)$ A produces a deflection of 60° in a tangent galvanometer. The reduction factor is

- 1) 2A
- 2) $\left(\frac{3}{2}\right)$ A
- 3) $\left(\frac{2}{\sqrt{3}}\right)$ A
- 4) $\left(\frac{2}{3}\right)$ A

59. In an A.C. circuit, V and I are given by $V = 150 \sin(150t)$ volt and $I = 150 \sin\left(150t + \frac{\pi}{3}\right)$ ampere. The power dissipated in the circuit is

- 1) 5625 W
- 2) zero
- 3) 106 W
- 4) 150 W

60. In the series $L-C-R$ circuit shown, the impedance is

- 1) 300Ω
- 2) 500Ω
- 3) 200Ω
- 4) 100Ω

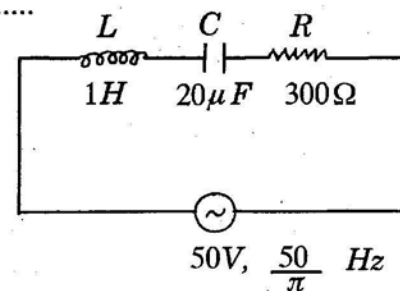

(Space for Rough Work)